

SIDEis



SIDEis ONE

Product Features

- Innovative, ultra compact, lightweight outdoor LED street lighting module designed for roadways, tunnels, pedestrian areas and architectural applications.
- Available in 11.6W ,12.6W, 15W & 16W.
- Lumen output up to 1639 lm with 5 special lighting distribution options.
- Available in CC & CV versions. 60,000hrs L70 lifetime reduces maintenance cost.
- IP66, IK09.
- CB, RoHS available.



Product Benefits

- Road lighting LED module concept designed to reduce the overall cost considering the enhanced road lighting efficiency, infrastructure costs, energy saving and maintenance costs.
- Excellent lighting distribution on the street. Thanks to the special optical system and the black PCB that decreases the random reflection of photons inside the device.
- Improving road efficiency and visibility in presence of fog due to low height application that minimizes the reflected & scattered light.
- Better control over light distribution in curved streets and roundabouts.

SIDEis Ordering Information

Example

S3	T0	7	40	G	13	F	1	D
MODEL	PHOTOMETRY	CRI	CCT	COLOUR	POWER	CONTROL MODE	CABLE LENGTH	MOUNTING
S3	TO Transversal	7 (70)	30 3000K	G grey	13W (350mA)	F constant voltage *	1 (1.5m)	T (inside guard-rail)
	FC Forward-Central	8 (80)	40 4000K	B black	16W (450mA)	E constant current **	2 (2.5m)	D (other mountings)
	LO Long							
	PR Pro-Beam-Right							
	PL Pro-Beam-Left							

* F constant voltage = one internal driver on board + external power supply for multiple luminaires

** E constant current = one external power supply for each luminaire

SIDEis requires a dedicated mounting bracket. Refer to section Accessory mounting systems



Dimensions (LxDxH) 102x73x76 mm

Weight (without cable) 0,4 kg

Materials

- Body in EN AB 46100 powder coated, anodised aluminum
- Optical group in transparent PMMA
- Gaskets in silicone foam
- Screws in AISI 304 (A2) steel
- Tightening torque for assembly screws 1.4±0.33Nm

Colours

- Standard colour brilliant grey RAL9007
- Other colours on request

Finishes

- Nanocoating technology for self-cleaning lens
- Endurance tested in salt fog ambient 1500h
- Marine grade option available

IP rating

IP66

IK rating

IK09

Operating temperature (Ta)

Da -40° up to 50°

Maximum wind exposed area

0,007 m²

Warranty

5 Years

Version with cable gland

To be installed with accessory mounting kit BRK-F, BRK-W, BRK-P (see section on page 9)

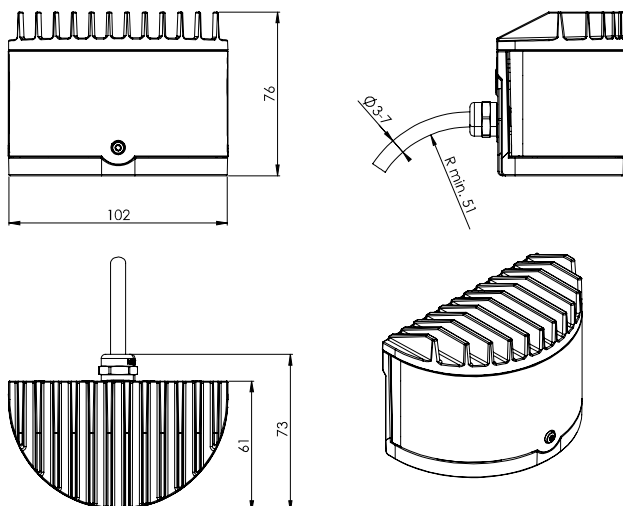

Version with cable grommet

To be installed with accessory mounting kit BRK-G (see section on page 9)

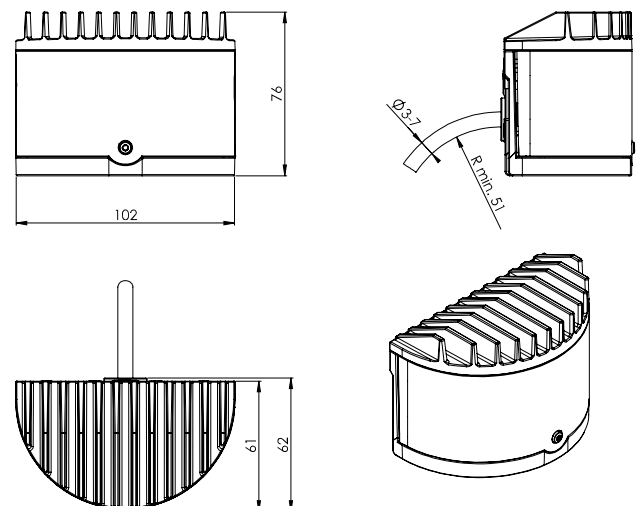

Led source

Type	Multi-chip LED board
CCT	3000K e 4000K
Colour rendering index	70, 80 CRI
Colour consistency	SDCM 3
Photobiological risk (for EN 62471:2008)	RG1
Average life @Ta 25°	50000h L90 B10



Features

Nominal voltage	@48Vdc ±5% (on board driver)
Power consumption (for 4000K CRI70 LED)	12.7W @350mA
Insulation class	III
Electromagnetic compatibility (EMC)	-40° up to 50°
Control systems	Fixed output
Cables and connections	Standard length 1.5m, Ø3+7mm, 2x0.75mm ² IP68 male and female connector on demand

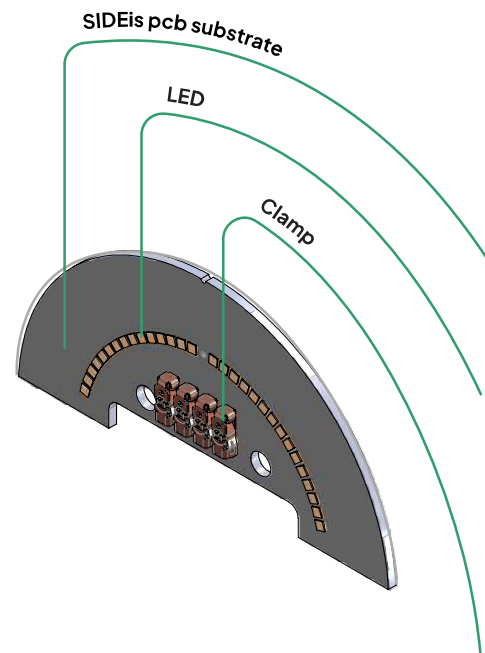

Power consumption vs. forward current

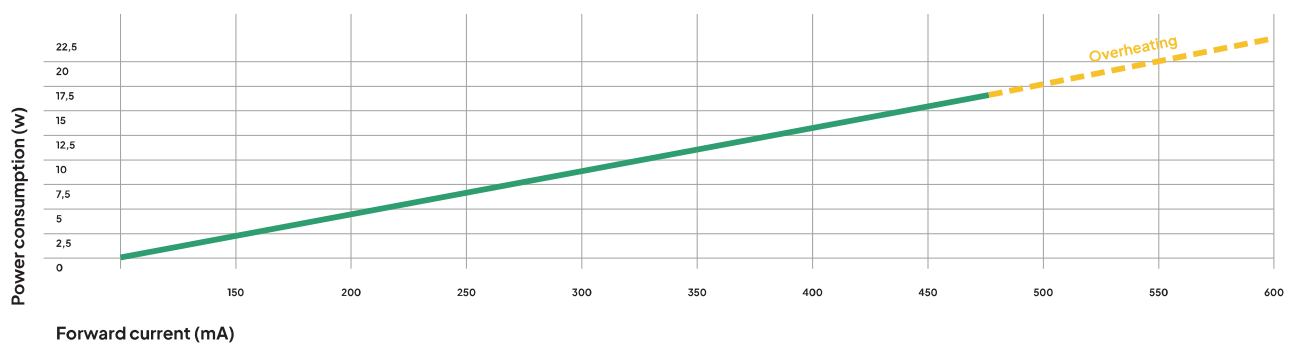

T0
Transversal

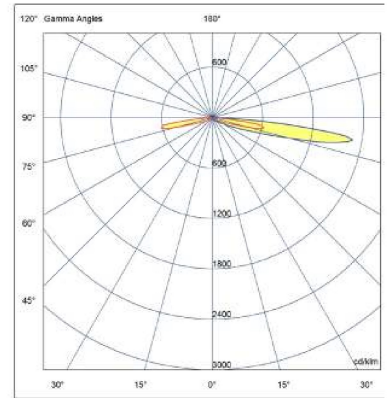
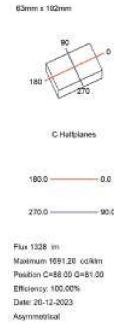
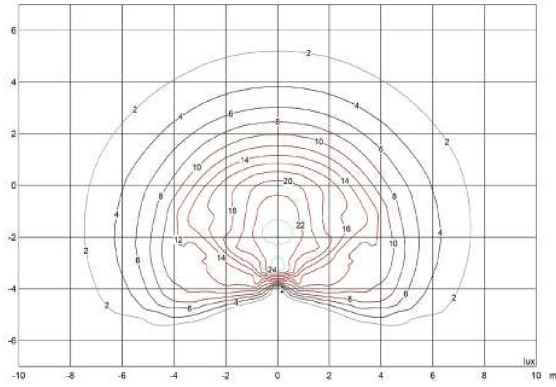

FC
Forward central

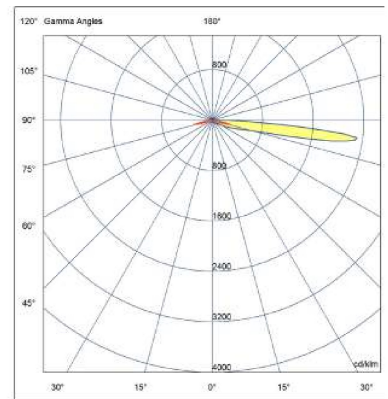
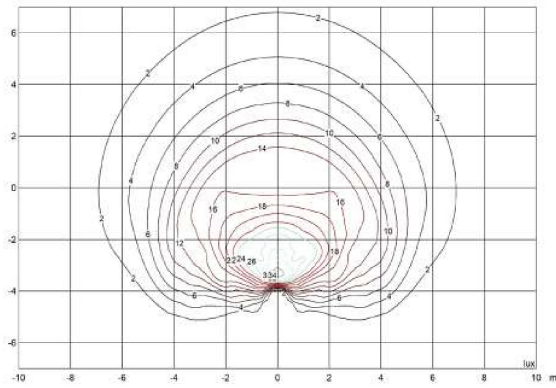

LO
Long

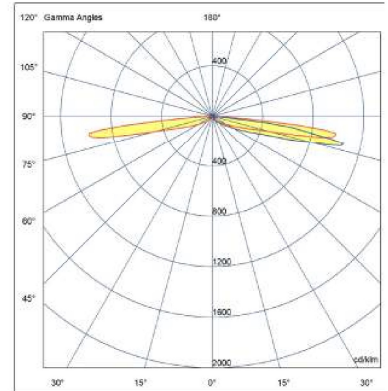
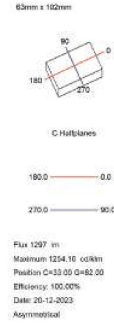
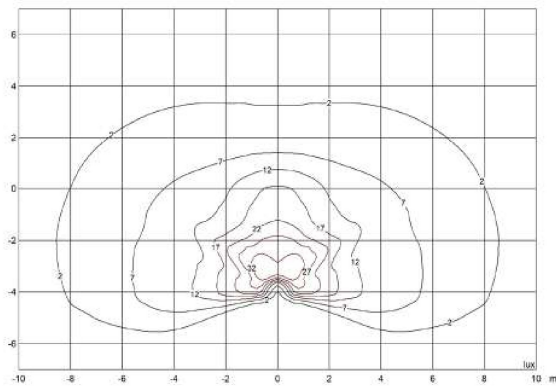

PR

Pro beam right

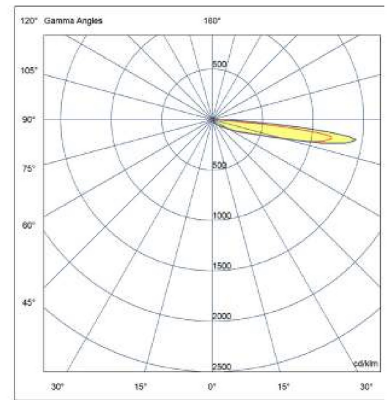
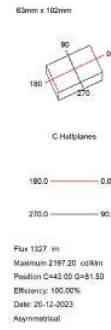
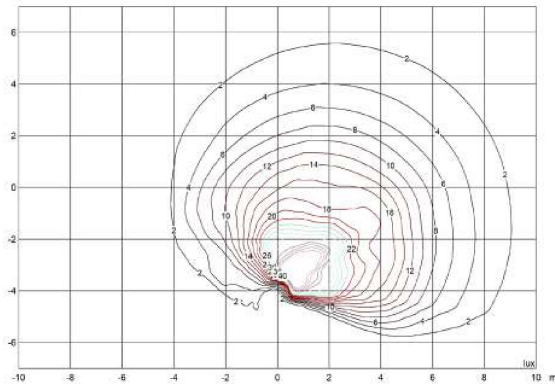

PL

Pro beam left

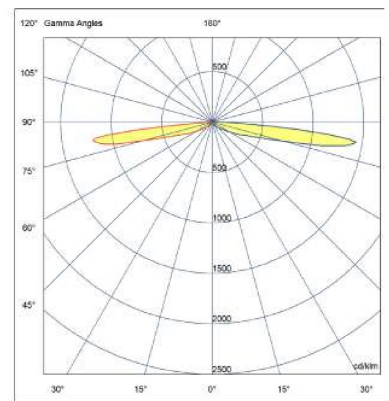
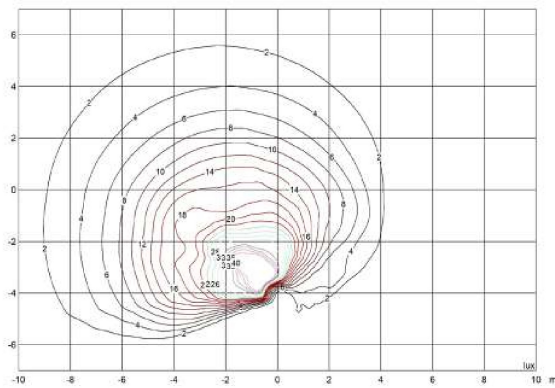

MODEL	PHOTOMETRY	CRI	CCT	POWER (W)	LED FORWARD CURRENT (mA)	FLUX (Lm)	VERSION
SIDEIS One	Transversal	70	4000K	11,6	350 mA	1328	CC
SIDEIS One	Forward-Central	70	4000K	11,6	350 mA	1385	CC
SIDEIS One	Long	70	4000K	11,6	350 mA	1297	CC
SIDEIS One	Pro-Beam-Right	70	4000K	11,6	350 mA	1327	CC
SIDEIS One	Pro-Beam-Left	70	4000K	11,6	350 mA	1327	CC
SIDEIS One	Transversal	70	4000K	15	450 mA	1617	CC
SIDEIS One	Forward-Central	70	4000K	15	450 mA	1686	CC
SIDEIS One	Long	70	4000K	15	450 mA	1579	CC
SIDEIS One	Pro-Beam-Right	70	4000K	15	450 mA	1616	CC
SIDEIS One	Pro-Beam-Left	70	4000K	15	450 mA	1616	CC
SIDEIS One	Transversal	70	4000K	12,6	350 mA	1242	CV
SIDEIS One	Forward-Central	70	4000K	12,6	350 mA	1295	CV
SIDEIS One	Long	70	4000K	12,6	350 mA	1213	CV
SIDEIS One	Pro-Beam-Right	70	4000K	12,6	350 mA	1241	CV
SIDEIS One	Pro-Beam-Left	70	4000K	12,6	350 mA	1241	CV
SIDEIS One	Transversal	70	4000K	16	450 mA	1512	CV
SIDEIS One	Forward-Central	70	4000K	16	450 mA	1328	CV
SIDEIS One	Long	70	4000K	16	450 mA	1385	CV
SIDEIS One	Pro-Beam-Right	70	4000K	16	450 mA	1297	CV
SIDEIS One	Pro-Beam-Left	70	4000K	16	450 mA	1327	CV
SIDEIS One	Transversal	70	3000K	11,6	350 mA	1327	CC
SIDEIS One	Forward-Central	70	3000K	11,6	350 mA	1617	CC
SIDEIS One	Long	70	3000K	11,6	350 mA	1686	CC
SIDEIS One	Pro-Beam-Right	70	3000K	11,6	350 mA	1579	CC
SIDEIS One	Pro-Beam-Left	70	3000K	11,6	350 mA	1616	CC
SIDEIS One	Transversal	70	3000K	15	450 mA	1616	CC
SIDEIS One	Forward-Central	70	3000K	15	450 mA	1242	CC
SIDEIS One	Long	70	3000K	15	450 mA	1295	CC
SIDEIS One	Pro-Beam-Right	70	3000K	15	450 mA	1213	CC
SIDEIS One	Pro-Beam-Left	70	3000K	15	450 mA	1241	CC
SIDEIS One	Transversal	70	3000K	12,6	350 mA	1241	CV
SIDEIS One	Forward-Central	70	3000K	12,6	350 mA	1512	CV
SIDEIS One	Long	70	3000K	12,6	350 mA	1241	CV
SIDEIS One	Pro-Beam-Right	70	3000K	12,6	350 mA	1512	CV
SIDEIS One	Pro-Beam-Left	70	3000K	12,6	350 mA	1241	CV
SIDEIS One	Transversal	70	3000K	16	450 mA	1512	CV
SIDEIS One	Forward-Central	70	3000K	16	450 mA	1241	CV
SIDEIS One	Long	70	3000K	16	450 mA	1512	CV
SIDEIS One	Pro-Beam-Right	70	3000K	16	450 mA	1241	CV
SIDEIS One	Pro-Beam-Left	70	3000K	16	450 mA	1512	CV

CC One external power supply for each luminaire

CV One internal driver on board + external power supply for multiple luminaires

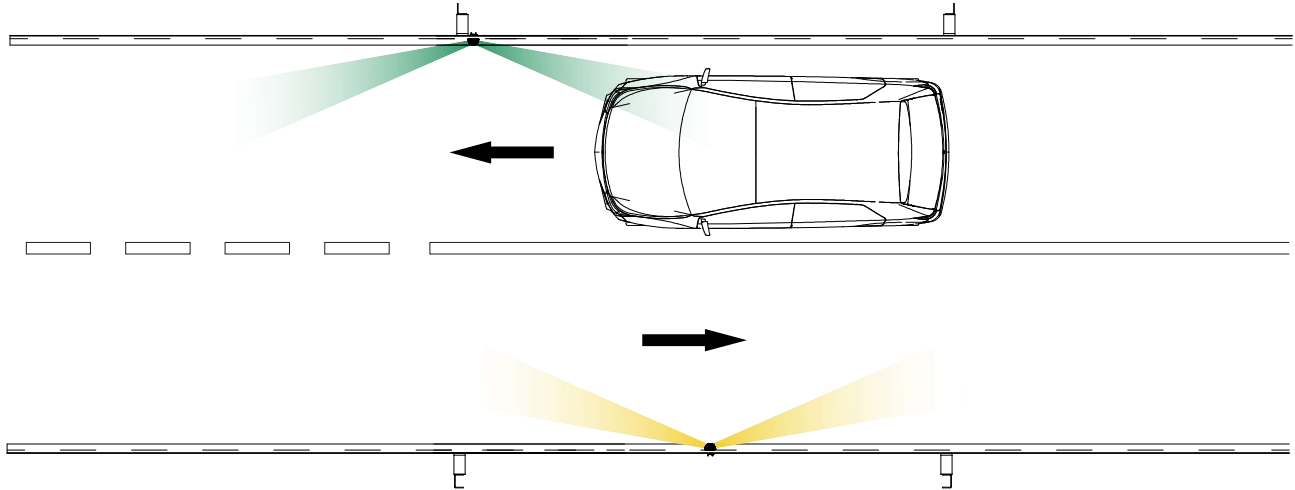

SIGNALLING MODULES

SIDEis can be equipped with additional reporting LED modules in amber and red colour.

This way SIDEis is transformed into a configurable road flasher essential in presence of fog, accidents, queues and each sort of danger on lane.

Photometric features of these modules allow SIDEis to achieve L2H class complying EN 12352:2006 standard (Traffic control equipment - Warning and safety light).

Each luminaire is able to dialogue with the contiguous ones in order to obtain specified signal sets (whip effect, for instance).

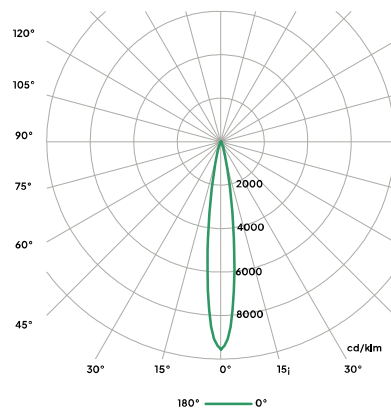
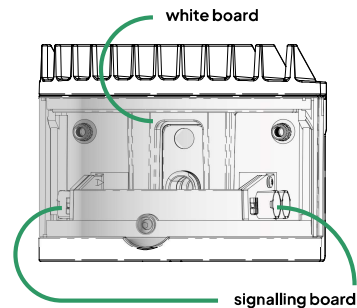

Power consumption (in continuous operation)	2x0.84W (green LED) 2x0.95W (yellow LED)
Optical group	PMMA lenses
Light beam (FWHM)	14°
Maximum intensity on axis	1566 cd (green) 1503 cd (yellow)
Output flux	158 lm (green) 151 lm (yellow)
Control systems	DMX

Accessory mounting systems Guard rail

SIDEis requires customized brackets to be mounted 0° according to the installation needed. Its accessory mounting kit can be designed and produced customized on request, typically in stainless steel.

The suggested mounting height is considered between 0.6 cm and 1 mt.

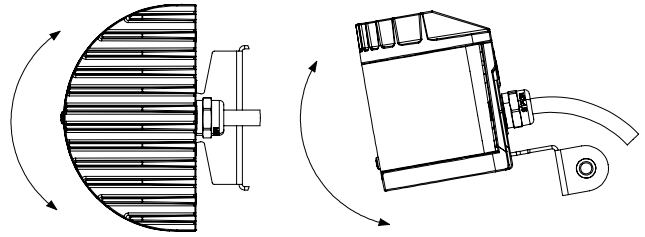

Guard rail BRK-G

With this mounting kit, the product must be ordered exclusively with cable grommet (T)

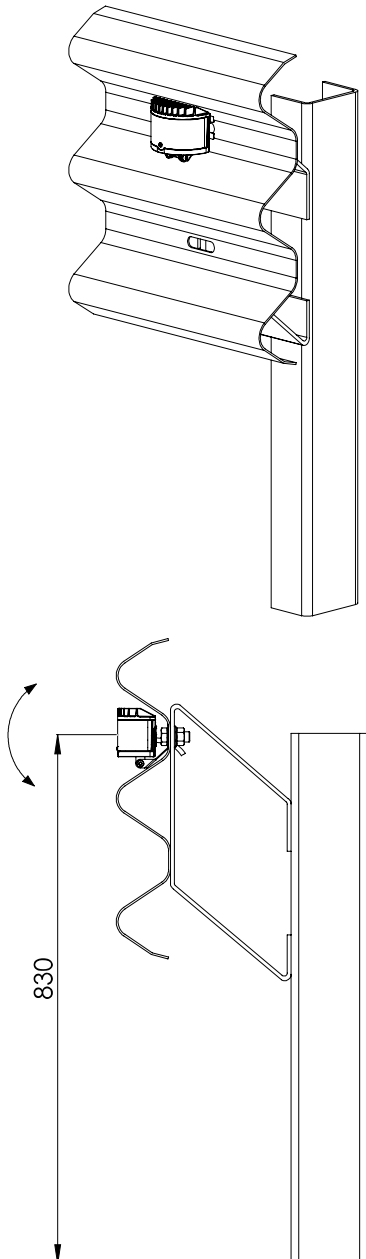

Guard rail BRK-F

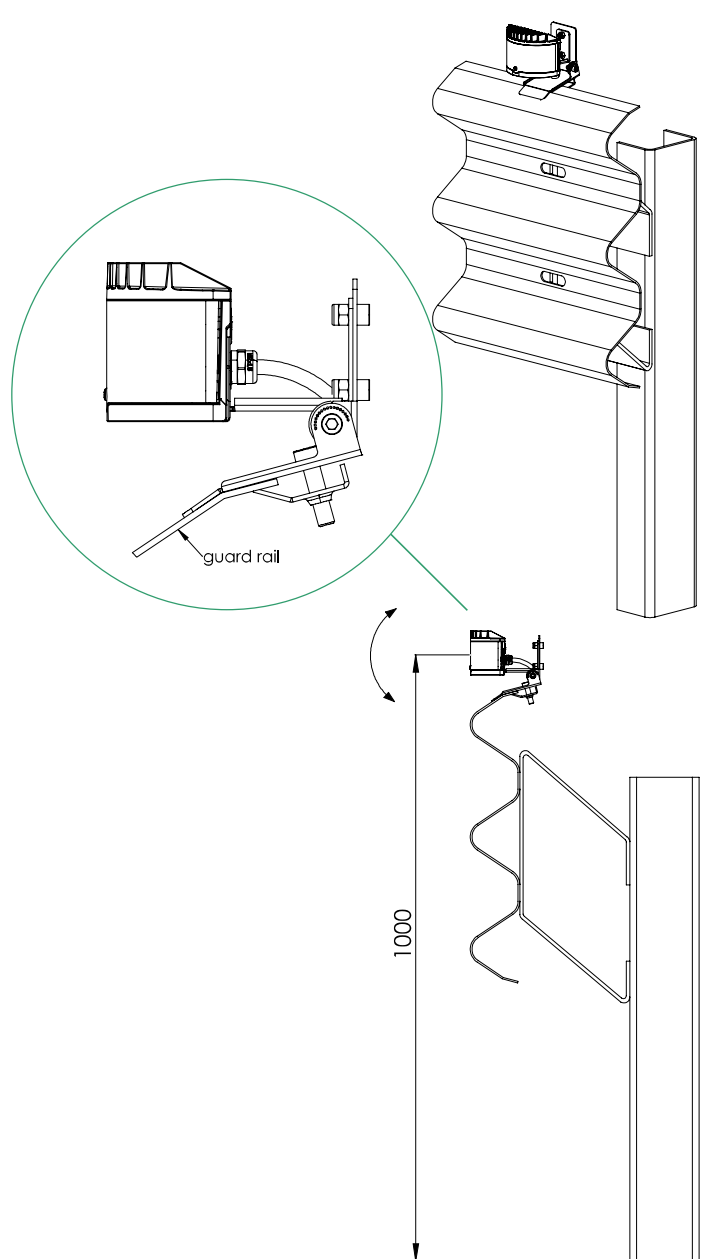

Surface / Wall BRK-W

Wall mounting

(Nogs not supplied)

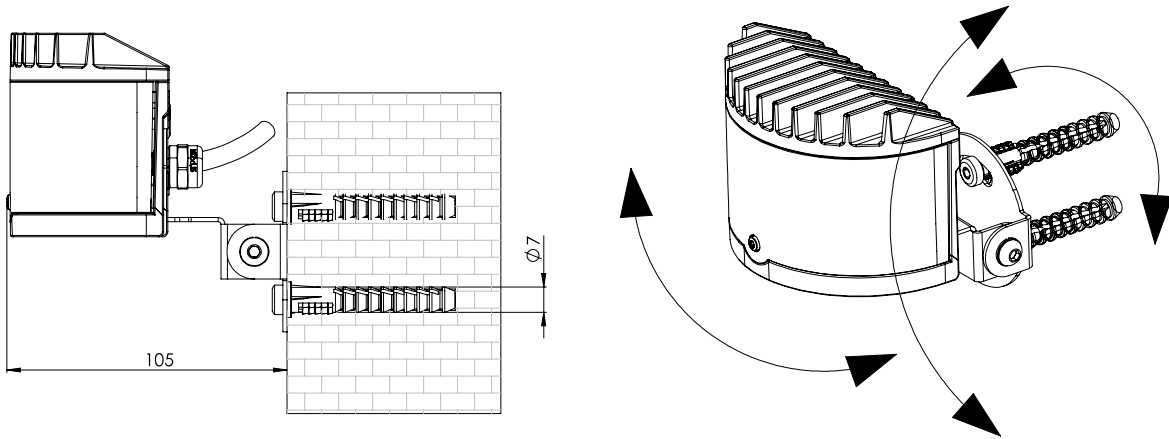

Low pole BRK-P

Support for $\varnothing 60$ pole

(Pole not provided)

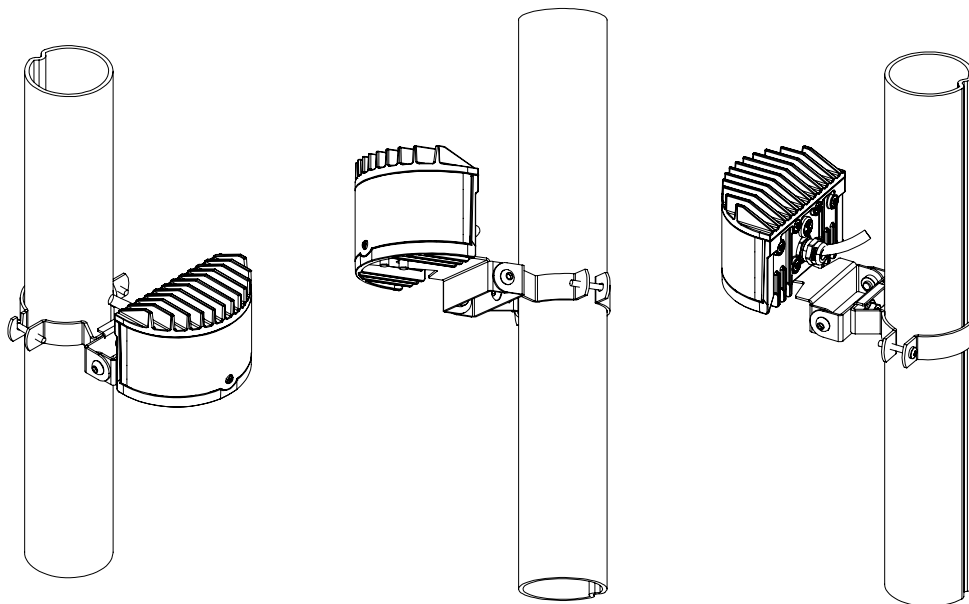

On column BRK-C

Column support - Available in 3 heights (88, 70, 30cm)

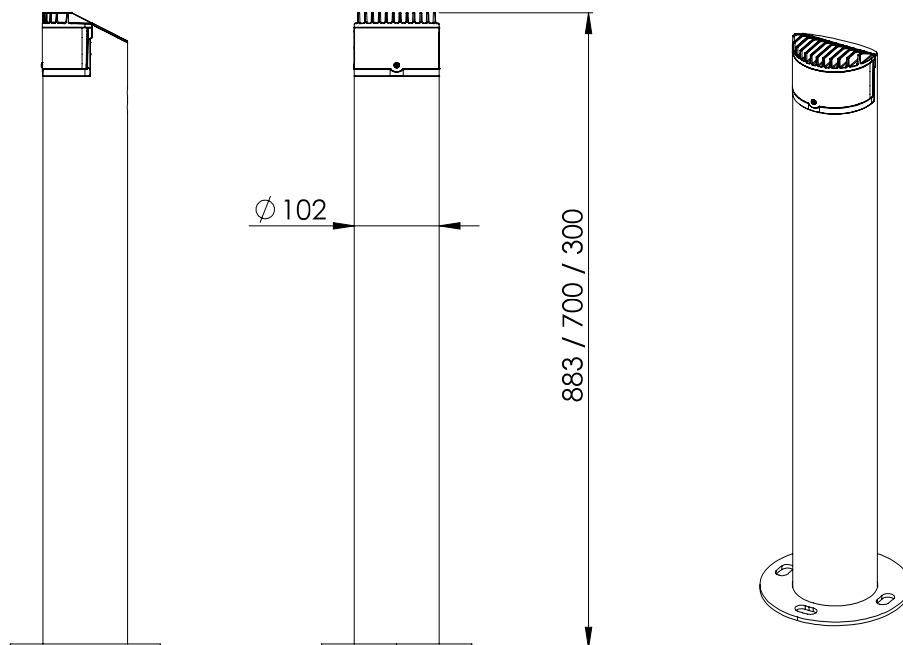
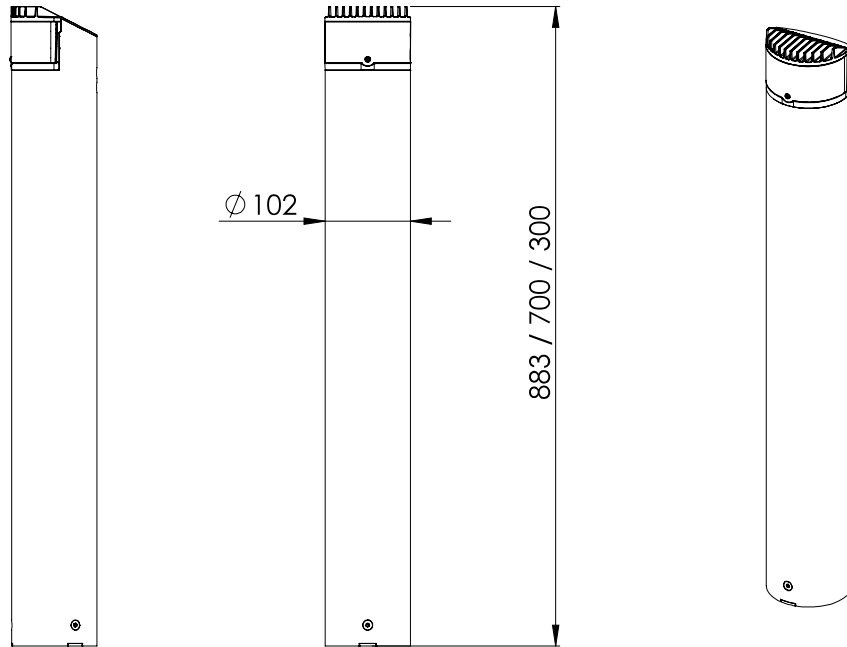

Do not use alcohol/ammonia-based products for cleaning the luminaire. They may cause cracking or deterioration of PMMA lens. Use water or dish detergent-like liquids to remove dirt and halos, together with a soft wet cloth. Use of water jets with maximum pressure of 100kPa is allowed.

If the external flexible cable or cord of this luminaire is damaged, it shall be exclusively replaced by the manufacturer or his service agent or a similar qualified person in order to avoid a hazard.

The light source contained in this luminaire shall only be replaced by the manufacturer or his service agent or a similar qualified person.

Use a SELV LED control gear with a maximum output of 48Vdc in compliance with IEC/EN 61347-1 and IEC / EN 61347-2-13, protected against short circuit and overload.

NO Ammonia-based products

NO Alcohol-based products

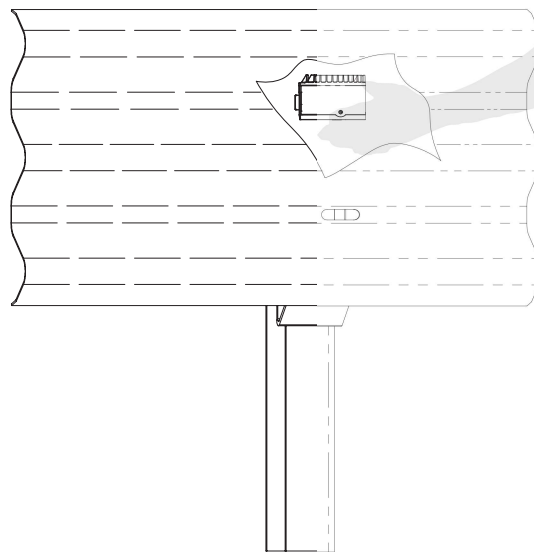

All values shown in this datasheet are to be considered nominal values subject to a tolerance of $\pm 5\%$.

Note: In order to guarantee constant updating of the product, SIDEis Srl reserves the right to make changes to this document without notice.



SIDEis S.r.l.

www.sideis.com
info@sideis.com